

1 Clamp assembly

1. Insert the clamp completely into the T-shaped tube, and tighten the quick release. Use a 13mm open-end wrench (provide for yourself) to adjust the nuts on quick release to suit the needs of tightness. (see picture 1)

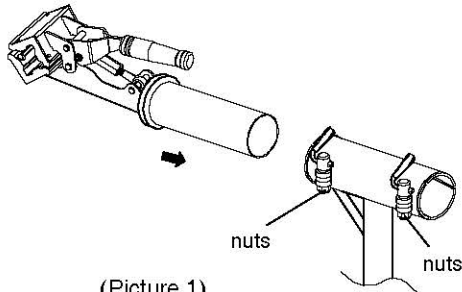

2 Tool tray assembly

1. Release the quick release.
2. Place the tool tray into the 2-ear (hole) collar. (see picture 2)
3. Fasten the quick release.

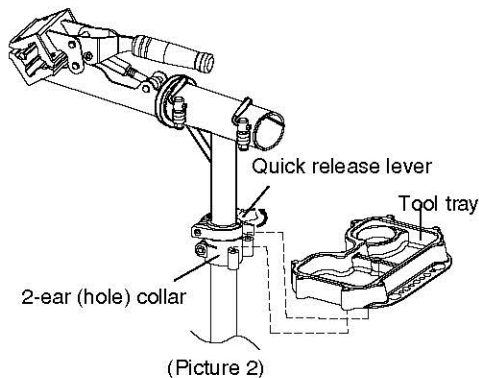

3 Adjust the clamp

1. Pull up the handle to open the clamp. (see picture 3)
2. Place frame (top tube, seat tube or standing tube) into the opening of the clamp.
3. Adjust the hex adjusting shaft to proper position then press down the handle to hold the tube.
4. Tighten the tube before starting to work. Check the tightness to avoid destroying the thin-walled-tube or carbon frame. Contact the frame manufacturer for suggested clamping place. (see picture 4)

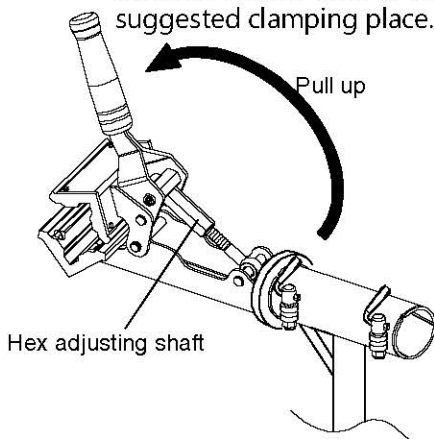

(Picture 3)

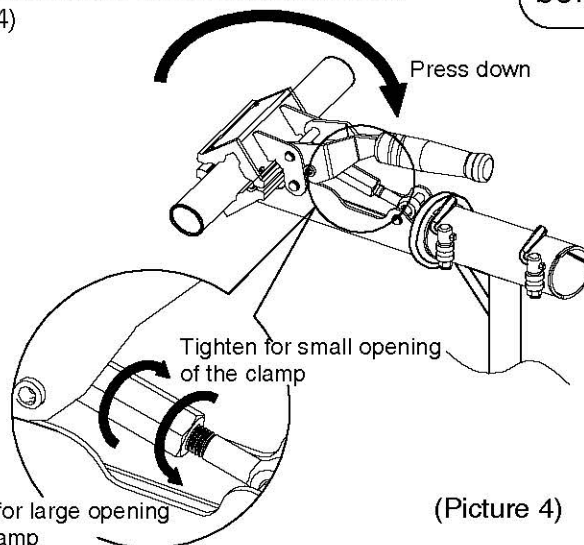

(Picture 4)

Visit Super B website for more information:
<http://www.superbiketool.com/>
Product → Work stands → 1. → TB-WS40+WS12

4 Floor base assembly (optional)

1. TB-WS12 floor base is optional for TB-WS40.
2. Please note the side of floor base with logo label is up side.

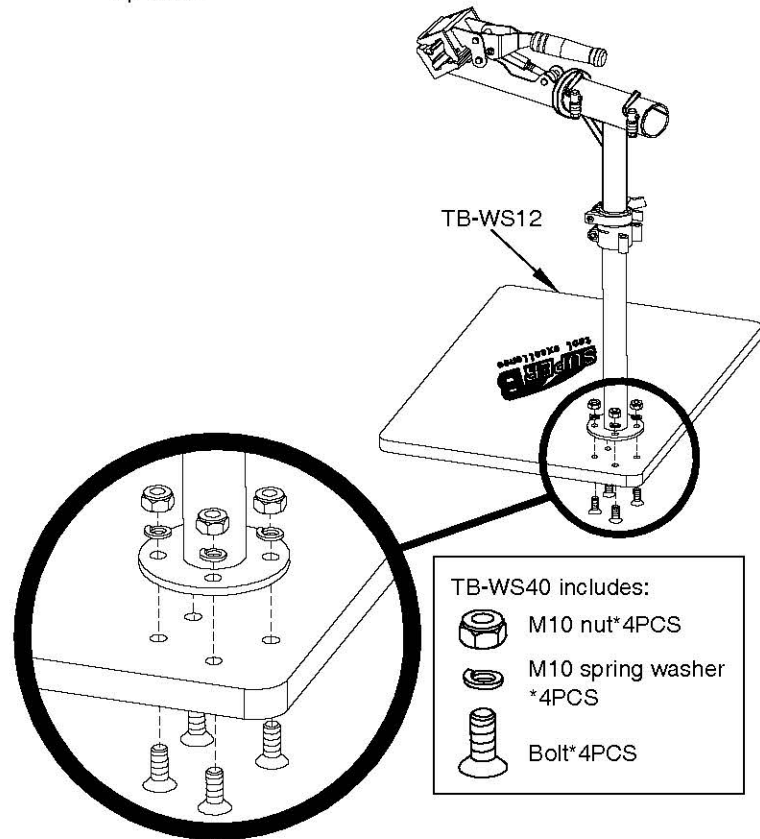

!
Make sure the tube has been tightened before use.

1 夾頭組合

1. 將夾頭完全穿入T型管，並將T型管上的快拆鎖緊。若緊度不足，可用13mm開口扳手（需自備）將螺帽鎖至需求的緊度。（如圖一所示）

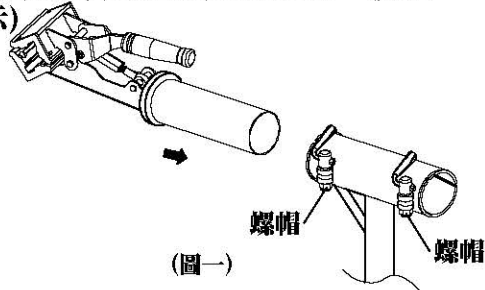

2 安裝工具盤

1. 打開快拆。
2. 將工具盤置入雙耳管束。（如圖二所示）
3. 關上快拆。

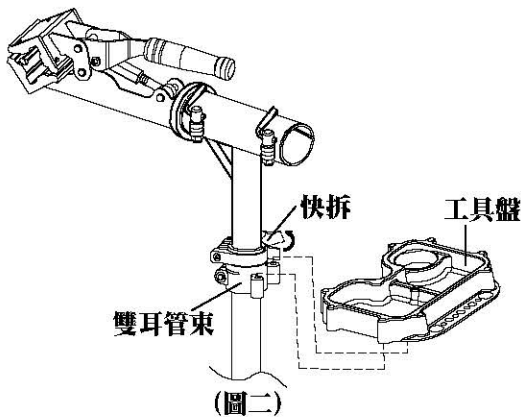

3 夾頭開口調整方式

1. 上拉握把，打開夾頭。（如圖三所示）
2. 將車架（可選擇車架上管/立管/座管）放入夾頭開口。
3. 依車管尺寸將六角調整軸旋轉至適當位置，以利握把下壓固定車管。
4. 注意：開始進行工作前，須夾緊車管，請自行衡量夾頭緊度，避免過度迫緊造成管壁薄或碳纖車架損壞。請自行洽詢自行車製造商建議的夾點。（如圖四所示）

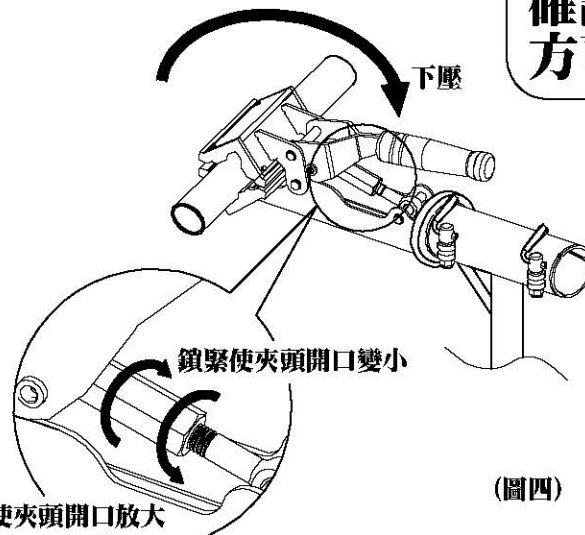
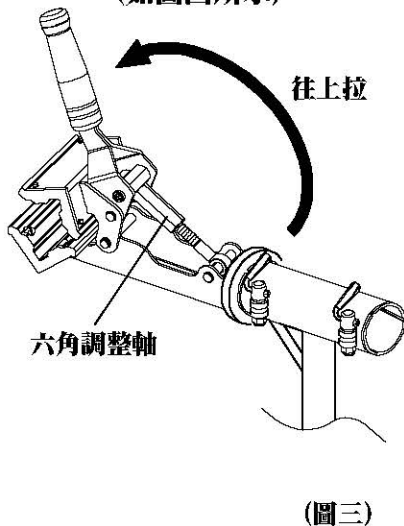

詳細資訊請至 Super B 官網觀看：
<http://www.superbiketool.com/>，點擊
Product → Work stands → 1. → TB-WS40+WS12

4 安裝基座 (選配)

1. 基座底板TB-WS12為選配配件。
2. 底板的LOGO面為正面，請注意安裝方向。

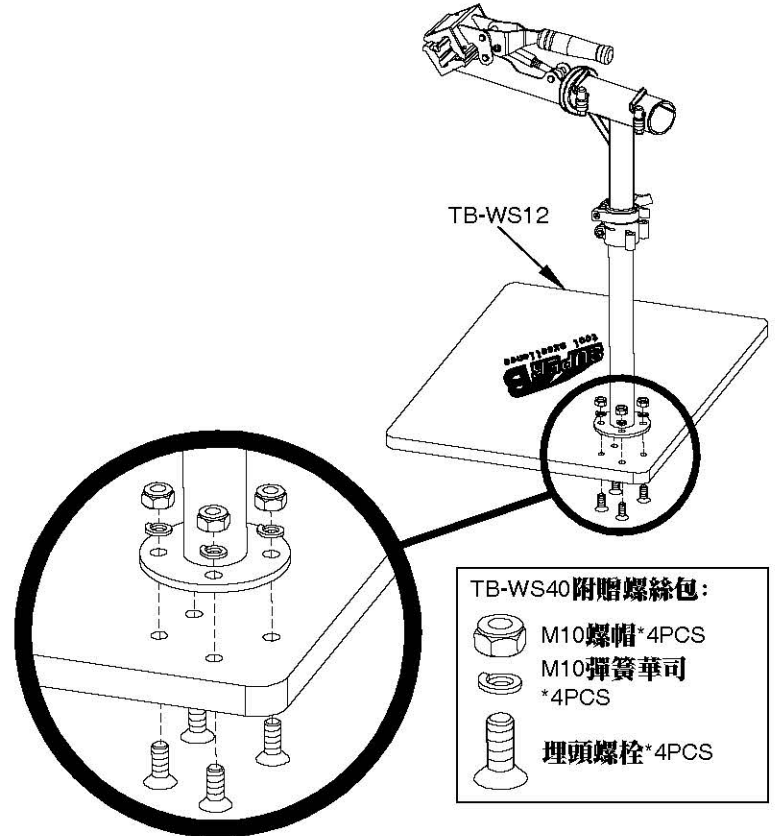

!
使用時，務必
確認已夾緊，
方可工作。